

# Venom Detector: A Smart approach to detect Snake Venom

Ajay Giri ,Dhanamma Jagli, Nilesh Shelar Ajit Panada, Vishal Gawde

VES Institute of Technology Chembur,  
Mumbai, India

**Abstract-** Snake bite is one of the major and common issues of the people living in rural areas. In India around 35000 – 45000 people dies because of snake bite. Those who survive the bite on the spot, subsequently die due to delay, unable to reach a hospital within the crucial golden hour or due to lack of treatment, resulting in overdose of anti-venom ,un-identification of snake i.e whether the snake is venomous or not. These all problem has Solution i.e an automatic Snake Venom Detector which will detect the venom within a fraction of second and it will send the report to the hospital which has facility of AntiVenom. Since there is lot of death because of doctors in rural areas are not able to identify the species of snake or whether the snake is venomous or not. So if snake bite is non venomous and given anti-venom then also victim will die because of anti-venom reaction. Also sometimes doctors ask the victim to bring the snake for identification by killing Also it takes lot of time to test whether snake is venomous or not through manual testing of blood samples. So in all this case venom detector will help to test for venom within fraction of second. So Venom Detector will reduce the death rate as well as burden of doctor.

**Keyword:** Venom Detector, Snake Bite, Dry bite,.

## I. INTRODUCTION

More than 2.5 lakh cases of snake bites are reported every year. In India around 35000 – 45000 people dies because of snake bite. South Asia is the world's most heavily affected region, due to its high population density, widespread agricultural activities, numerous venomous snake species and lack of functional snake bite control programs. Snake bite management remains unsatisfactory in this region. Diagnostic tests for snake species identification do not exist and treatment mainly relies on the administration of antivenoms that do not cover all of the important venomous snakes of the region. The main problems of people in rural areas is that they sometimes people have more trust on false claims of treatment and most of the times people fall prey to quacks' treatment. Since there is lot of death because of doctors in rural areas are not able to identify the species of snake or whether the snake is venomous or not. All snakes are not venomous – so every snakebite is not going to result in death. Even a venomous bite is not always fatal – because the severity of snakebite depends on many factors like the size of the snake, whether the bite could be completed, whether it was a dry bite or not, the age, physique and affected limb of the victim. So if snake bite is non venomous and given anti-venom then also victim will die because of anti-venom reaction. Also sometimes doctors ask the victim to bring the snake for identification .Also it takes lot of time to test whether snake is venomous or not through manual testing of blood samples. So in all these cases venom detector will help to

test for venom within fraction of second and will send the report to nearest hospital which has Anti Venom available with them by using Intranet or some other types of network depending upon the situation. In case the if snake bite is not venomous then local doctor only will give some medicine for infection and victim need not to go to any big hospital for taking anti venom. So Venom Detector will reduce the death rate as well as burden of doctors. Venom Detector, by using Biosensors technology will detect whether snake is poisonous or not. Biosensor is a device that can detects and measures and communicates informative results about physiological changes or the presence of specific chemical or biological materials.Any device that uses specific biochemical reactions to detect chemical compounds in biological samples .A sensor that integrates a biological element with a physiochemical transducer to produce an electronic signal proportional to a single analyte which is then conveyed to a detector. Venom Detector will work in similar way as Diabetes Detector works.

## II.CURRENT SYSTEM, HOW VENOM IS DETECTED

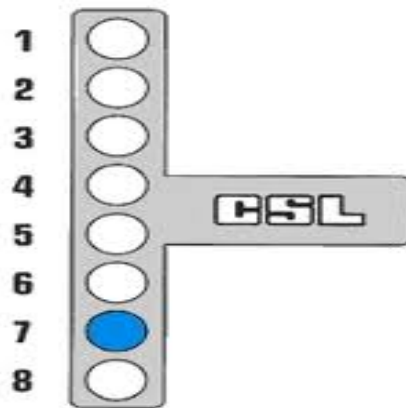

### Current Venom Detection Techniques

In current scenario the Venom Detection is done by old and tradition method of detecting the venom by taking the

blood sample from the victims. There are many methods for detecting the Snake Venom for example ELISA , Snake Venom Detection Kit (SVDK).But these methods take lots of time for testing the samples and producing the result.

**Disadvantage of current System :**

- 1) Current system, It takes lots of time to test or to check whether the snake is venomous or not.
- 2) There is no strong method to identify the species for snake i.e venomous or not in quick time.
- 3) Some times doctors ask victims to bring the snake for identification purpose.
- 4) Because there is no quick treatment ,people falls in myths and trust on false claims of treatment and most of the times people fall prey to quacks' treatment.
- 5) In current system the testing is done manually and then report is prepared ,So there is chances that data can be wrong or misprinted .

The Rough model of Vemon Detector will work by biosensor technology for detecting the venom and species of snake. This model van be modified or changes can be made as per the need. Test strip is used to take the sample of blood from victim and the result will be shown to display area as well after the test is done the report will be generated and It will be sent the nearest hospital which has the facility of antivenom i.e either monovalent Antivenom or polyvenom antivenom.The Detector will generate a report which will include whether snake is venomous or not and if venomous, then which type of species it belongs to. Since using monovalent is more effective than polyvalent .

A **biosensor** is an analytical device that is used for the detection of an analyte , that combines a biological component with a physicochemical detector. As It show, input samples is given to system then by using biosensor technology it produce the output which is displayed of Display device.

**How Biosensor works [2]**

- a) The sensitive biological element (e.g. microorganisms, tissue, organelles, Receptors, enzymes, antibodies, nucleic acids, etc.), a biologically derived material or component that interacts (binds or recognizes) the analyte under study. The biologically sensitive elements can also be created by biological engineering.
- b) The transducer or the detector element (works in a physicochemical way; optical, piezoelectric, electrochemical, etc.) that transforms the signal resulting from the interaction of the analyte with the biological element into another signal (i.e., transduces) that can be more easily measured and quantified;
- c) The biosensor reader device with the associated electronics or signal processors that are primarily responsible for the display of the results in a user-friendly way.

**III. PROPOSED SYSTEM**

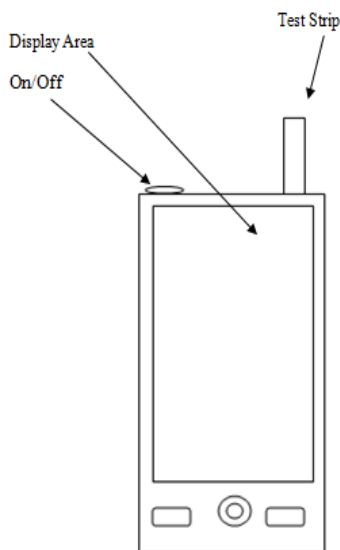

**Rough model of Snake Venom Detector**

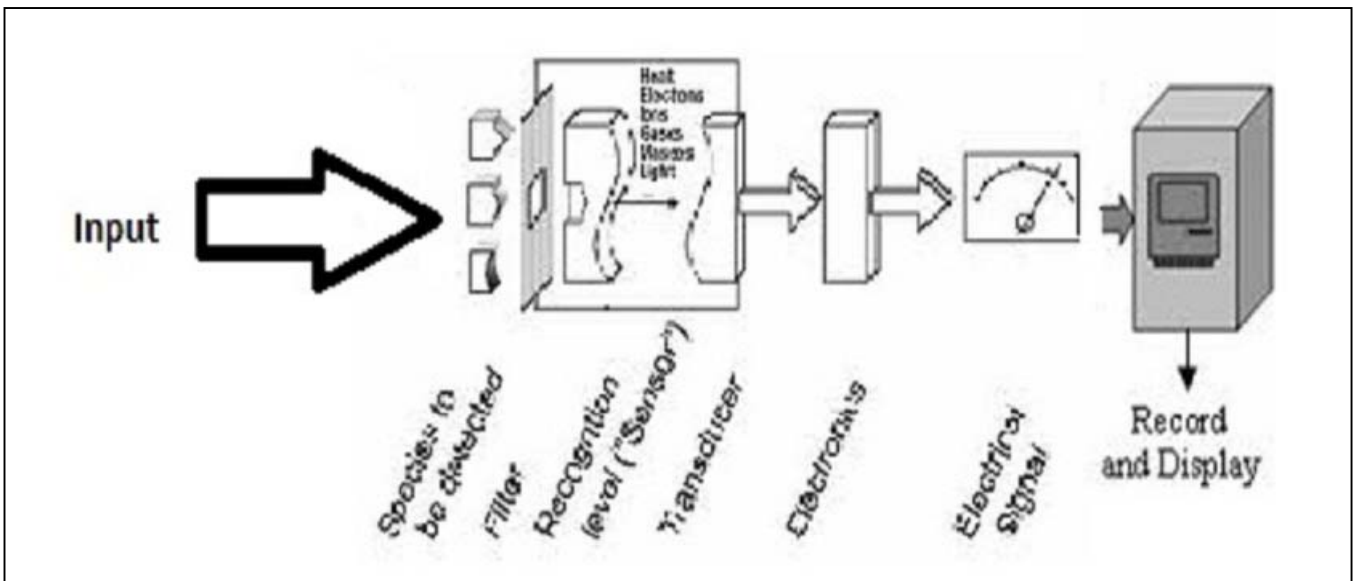

**How biosensor works in general**

### **Advantages of Proposed system**

- 1) Proposed system will reduce the death rate due to snake bite in rural areas.
- 2) Proposed system, It takes very less time for test i.e within seconds or minutes It will check whether the snake bite is venomous or not
- 3) Venom Detector will identify the species of snake which will help doctor to give polyvalent antivenom to victims.
- 4) It reduces the overhead of doctors as well as Victims. No need to bring the dead snake for verification for their species.
- 5) With proposed system people in rural areas will not believe in myth and will not trust on false claims of treatment and people will not fall prey to quacks' treatment for snake bite.
- 6) The Venom Detector will automatically generate the report of test, This will remove the error caused due to human at the time of data entries for report generation.

### **CONCLUSION**

Thus by using snake venom detector we reduce the death rate caused by snake bite also It will reduce the burden of doctors of identifying the species of snake. Venom detector is an automatic device will detect the presence of venom in the victim as well as It will identify the species of Snake making the treatment easy and perfect.

### **REFERENCES**

- [1] <http://www.teachengineering.org>
- [2] <http://en.wikipedia.org/wiki/Biosensor>
- [3] [www.ijrap.net](http://www.ijrap.net)
- [4] <http://www.physicianbyte.com/SnakesVenomAndSnakeBite.aspx>
- [5] [http://www.onhealth.com/snake\\_bites/article.htm](http://www.onhealth.com/snake_bites/article.htm)
- [6] <http://www.modernmedicine.com/modern-medicine/news/snakebite-how-do-you-know-when-its-poisonous>
- [9] <http://www.modernmedicine.com/modern-medicine/news/snakebite-how-do-you-know-when-its-poisonous>
- [10] <http://www.auroville.org/comingtoav/snakebite.htm>
- [11] <http://online.wsj.com/article/SB124208165196508345.html>
- [12] <http://www.news-medical.net/health/Biosensor-Principles.aspx>